	DOCUMENT NO:	CDS-L620100-00XXXX	VER:	1.0
	L6 Fino Power Supply			EFFECTIVE DATE:
APPROVAL:	ECO-318	Jupiter PN(s):	L620100-00XXXX	PAGE 1 OF 4

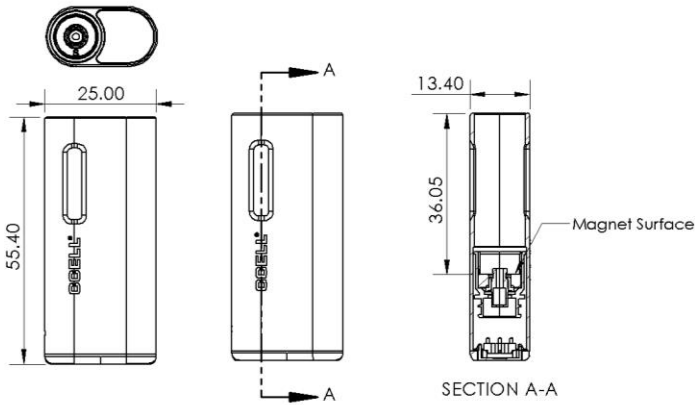

Figure 1: Mini battery

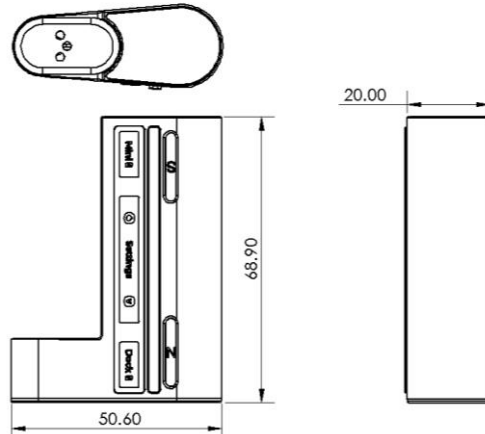

Figure 2: Power dock

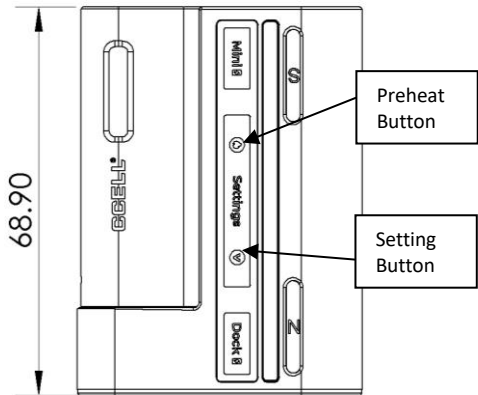

Figure 3: Entire device (No leather cover)

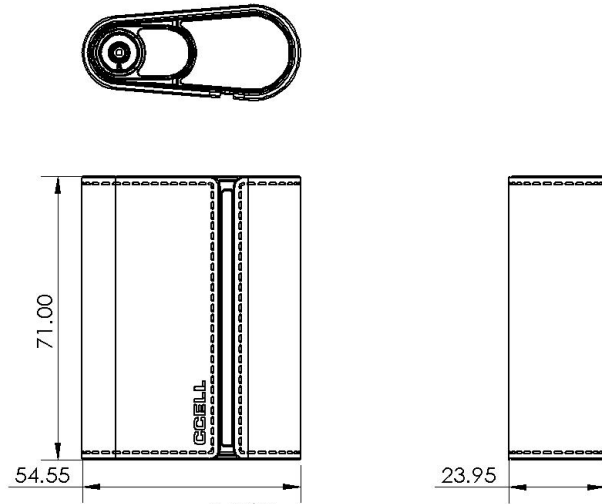
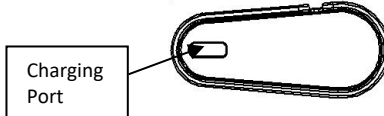

Figure 4: Entire device (With leather cover)



Charging Port

**All dimensions are in mm*



DOCUMENT NO:

CDS-L620100-00XXXX

VER:

1.0

L6 Fino Power Supply

EFFECTIVE DATE:

11/27/2023

APPROVAL:

ECO-318

Jupiter PN(s):

L620100-00XXXX

PAGE 2 OF 4

Electrical Specifications

Battery Cell Capacity	Mini battery: 190mAh Power dock: 1000mAh
Output Voltage with 1.4Ω load	Preheat: 1.8Vrms Setting 1: 2.2Vrms Setting 2: 2.4Vrms Setting 3: 2.6Vrms Setting 4: 2.8Vrms Setting 5: 3.0Vrms Setting 6: 3.2Vrms Setting 7: 3.4Vrms Setting 8: 3.6Vrms
Max. Current Output	Mini battery: 3000mA Power dock: 8A
Max Charging Current	Mini battery: 400mA Power dock: 1000mA
Activation Time	0 – 14 seconds ($\pm 1s$) <i>Other time durations available by request</i>

User Interface

Cartridge Attachment	Magnetic; supplied with 2 adapters for 510 threaded connections
Activation	Breath Actuated
Notification	LED
Charging type	USB type C

User Function Guide

See Annex A

Safety Features

Short-circuit Protection	When the resistance of loading less than $0.8(\pm 0.2)\Omega$, the power will cut off, and the Mini battery LED turn on 2S. If the Mini battery is connected to the power dock, all middle 8 LED on the power dock turn on 2S.
Over usage Protection	When any time suctioning lasts for more than $14(\pm 1)S$, the power will cut off, and the Mini battery LED flash two times then turn off. If the Mini battery is connected to the power dock, the power dock returns to standby light mode.
Low power Protection	When the mini battery is not connecting to the power dock, and when the battery voltage of the mini battery is lower than 3.3V, output will be de-energized, mini battery LED will flash 10X. When the mini battery is connecting to the power dock, and when battery voltage of the mini battery is lower than 3.3V, output will be de-energized, top 3 LEDs on the dock will flash 10X. When the battery voltage of the power dock is lower than 3.3V, middle 8 LEDs on the dock will flash 3X.
Open circuit Indication	When the load is a open circuit, the mini battery LED will flash 5X while puffing or preheating the device. If the mini battery is connecting to

	DOCUMENT NO:	CDS-L620100-00XXXX	VER:	1.0
	L6 Fino Power Supply			EFFECTIVE DATE:
APPROVAL:	ECO-318	Jupiter PN(s):	L620100-00XXXX	PAGE 3 OF 4

	the power dock, all LEDs on the dock will flash 5X.
Li-ion Battery Cells	Cells meet the requirements of the UN Manual of Tests and Criteria for Li-ion batteries; section 38.3. Jupiter power supplies are not required to be classified as Dangerous Goods when packaged properly for transport by sea, air, or ground due to their small capacity and containment within the device
Cell Containment	Cells are enclosed in metal housings to protect the battery cell from contact with external elements that may cause damage to the cell under normal usage conditions and transportation. Cells are not accessible to the user without permanent damage to the unit
Overcharge Protection	Charging control is on-board, not contained in a separate charging adapter. The onboard controller shall permit the device to remain connected to power when fully charged without the risk of damage to the battery cell. Recommended to not leave batteries unattended while charging, not to charge overnight and, to remove batteries from chargers when fully charged.

Operating Temperature and Humidity	<ul style="list-style-type: none"> ○ Charging temperature 10 - 45°C ○ Working temperature: 0 - 60°C ○ Operating humidity range 35% - 70%
Storage Temperature and Humidity	<ul style="list-style-type: none"> ○ Storage temperature 23±5°C ○ Storage humidity range 35% - 70%
Certifications	<ul style="list-style-type: none"> ○ RoHS ○ CE ○ FCC

Compatibility

The Fino by CCELLTM Power Supply uses a magnetic connector. Two adapters for “510” connections (PN: L68000-7100) are supplied making the Fino compatible with most cartridges designed for use with breath actuated power supplies.

Although the term “510” is widely used in the vaping industry to designate a compatible connection, a published specification for a 510 threaded connection does not exist. Not all products that utilize a “510” connection are compatible with products from other manufacturers. While all these products utilize an M7 threaded connection, the similarity does not extend beyond the thread pattern. The depth of the electrical contacts, the air inlet locations, and other features may vary from manufacturer to manufacturer.

	DOCUMENT NO:	CDS-L620100-00XXXX	VER:	1.0
	L6 Fino Power Supply			EFFECTIVE DATE:
APPROVAL:	ECO-318	Jupiter PN(s):	L620100-00XXXX	PAGE 4 OF 4

Annex A – User Function Guide

- a. Actuation Indication
 - i. When the mini battery is not connecting to the power dock, mini battery LED will stay on while the device is activating.
 - ii. When the mini battery is connecting to the power dock, all LEDs on the power dock will show a flow light effect while the device is activating.
- b. Power Dock Charge Indication
 - i. Battery capacity <40%, the first white light flashes once, and then blinks.
 - ii. Battery capacity > 40% and < 70%, after the first and the second LED lights show a flow light effect, the first LED light will stay on, and the second LED light will blink.
 - iii. Battery capacity >70% and <100% after the three LED lights show the flow light effect, the first and second LED lights stay on, and the third LED blinks.
 - iv. Remove the charger, all LED lights will extinguish.
 - v. When the battery is fully charged, if the leather cover is opened, all LED lights will be steady on.
- c. Mini Battery Charge Indication
 - i. When the power dock detects that the mini battery's voltage is lower than 3.9V, the charging will be automatically started. Top 3 LEDs will display charging indication, bottom 3 LEDs will display remaining battery volume of the power dock. If the leather cover is closed, all lights will turn off after 10s. If the leather cover is opened, all lights will turn off after 10 minutes.
- d. Pre-heat
 - i. When the preheating is off, press the preheat button to enter the preheating function.
 - ii. When the preheating is on, press the preheat button or the output adjustment button to end the preheating function.
 - iii. When in the preheating state, all middle 8 LED lights blink, and the preheating lasts for 10S. After that, the output stops, and the LED lights resume standby mode.
 - iv. When inhaling in the preheating state, the product will exit the preheating state and enter inhaling state.
- e. Battery and Setting Query
 - i. When the dock is not charging by USB, while opening the leather cover, the bottom 3 LEDs will display the remaining battery volume of the dock, the middle 8 LEDs will display the current voltage output setting, and if the mini battery is charging, the top 3 LEDs will display the charging indication, if the mini battery is full, the top 3 LEDs will display the battery volume of the mini battery.
 - ii. When the dock is charging by USB, while opening or closing the leather cover, all LEDs will display charge indication.
- f. Output Power Switch
 - i. Press the "Setting adjustment" button once to increase the output voltage setting by 1 level. The voltage setting cycle is 6-7-8-1, and the corresponding LED will be on for 2 seconds.
 - ii. Press and hold the "Setting adjustment" button to increase the output voltage setting continuously. The voltage setting cycle is 6-7-8-1, and the corresponding LED will be on until the button is released.